



Owner's Manual and Manufacturer's Warranty Information for Rolling Shutters

Dear Valued Customer,

Thank you for your purchase of your new Rollac rolling shutter system. All materials used are top quality and suitable for their purposes.

Rollac places great emphasis on the quality of its products and on providing maximum satisfaction for customers and end users. Please familiarize yourself with this owner's manual, which covers operating and maintenance instructions of your shutter as well as the manufacturer's warranty information.

General Operating Instructions for Manual and Motorized Rolling Shutters

Operation During Winds

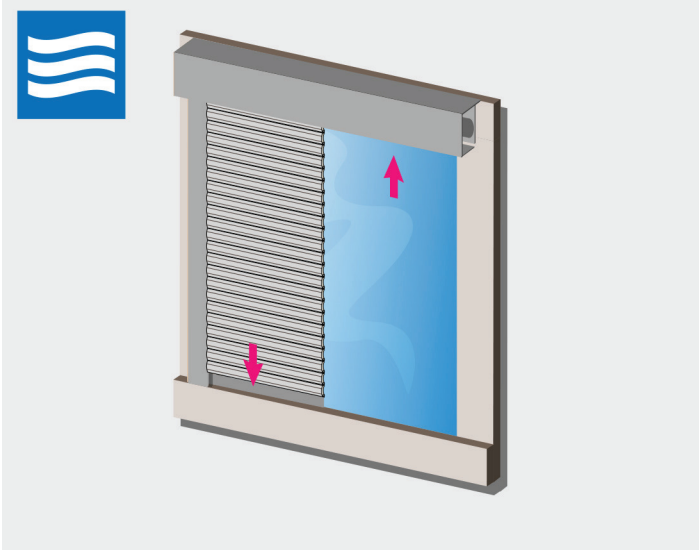

Make sure that rolling shutter is completely closed or completely open during high winds. Keep windows closed.

Operation in the Heat



If you use your rolling shutter in a hot climate, we recommend opening the curtain slightly. This will allow for back ventilation. If your rolling shutter is equipped with light slits, you can set the curtain in a light slit position.

Operation In Cold Climates

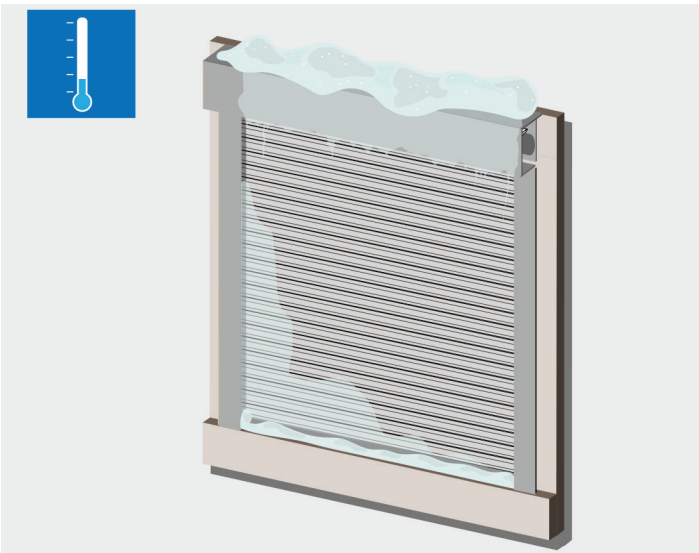

During cold weather, the curtain can freeze, either inside the housing or onto the rails. Do not use the shutter, leave in current position and avoid any forceful operation. Wait until rolling shutter is defrosted. Then it can be used again.

Do Not Hang Weight Onto The System

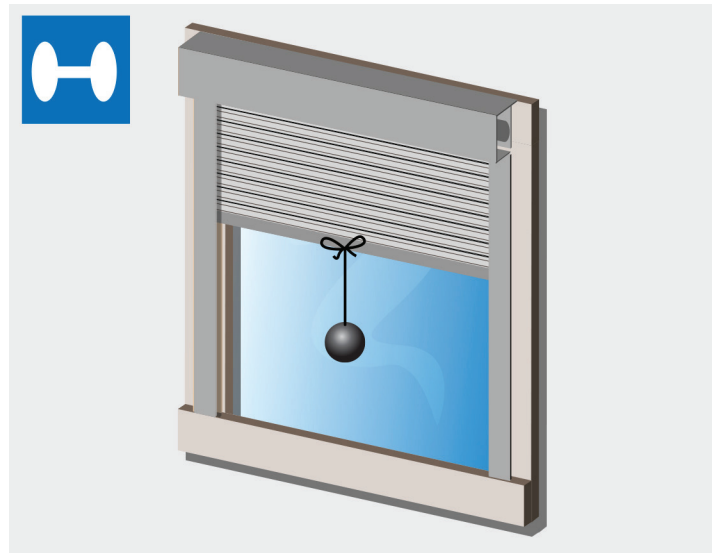

Do not add or hang any weights to the rolling shutter.

General Operating Instructions for Manual and Motorized Rolling Shutters

Operating Path Of Rolling Shutter



Make sure there are no obstacles in the path of the rolling shutter while the shutter is in operation.

Do Not Push Up Rolling Shutter

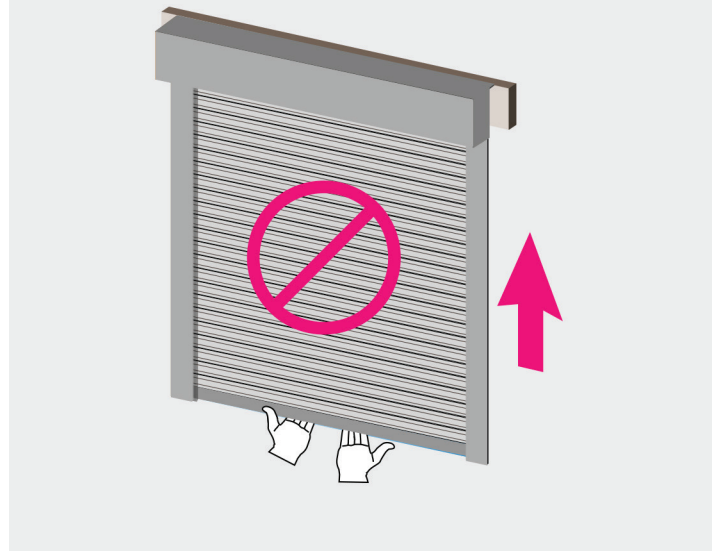

Never push up the rolling shutter. This could cause malfunction.

Please follow these safety guidelines

- Any modification to the rolling shutter requires the written permission of the manufacturer.
- Never stand on, climb on, or hang from the rolling shutter.
- Do not place your hands in moving parts or inside guide rails.
- When selling the building, please pass the information on as they contain the service and maintenance instructions.

Look For Debris

- Debris Build Up: If shutter has been in down position for a longer period of time, such as for vacation homes, or has been exposed through rough weather conditions, inspect shutter first. Make sure there is no debris or other build up that might roll into the housing. Clean or hose off if necessary. Make sure that there is no debris in the guide rails that could cause jamming of shutter.
- Hurricane: If shutter has been used during a hurricane, inspect shutters carefully before reopening. Make sure there is no debris blocking the operation. Make sure that shutter is still in operable condition.

Recommended Operation

Your rolling shutter is designed to be operated on a daily basis. The normal use is two cycles per day. One cycle is a fully open and close sequence. We recommend operating your rolling shutter at least once a month for optimal performance.

Instructions for Motorized Rolling Shutters

Limit Access To Rolling Shutter Controls

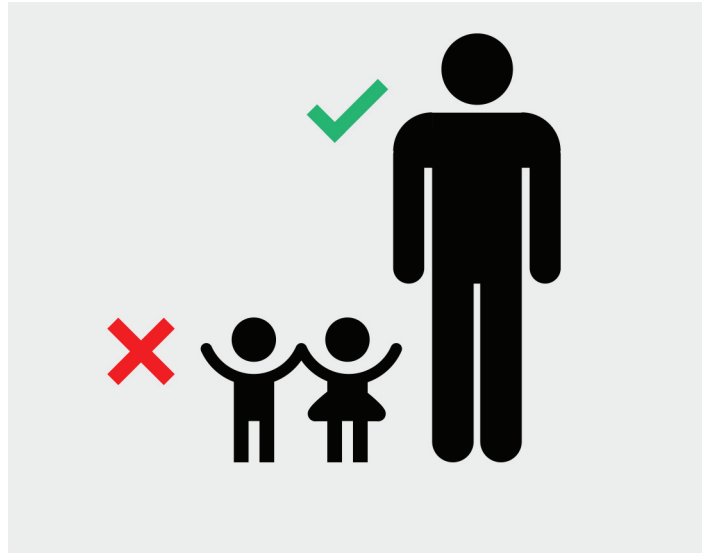

Limit the access of the operating controls and keep remote controls or switches out of reach of children.

Automatic Control

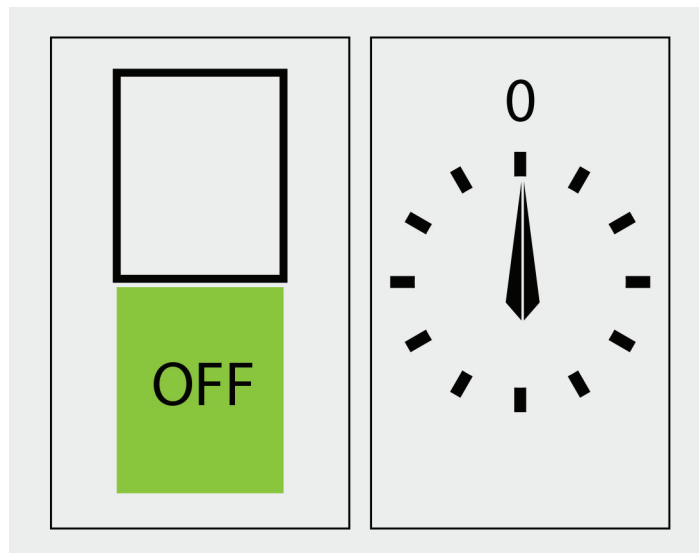

Switch off automatic controls in the winter or when away from home. Examples for an automatic control can be sun sensors, timers or integration into home automation.

Controlling Your Rolling Shutter Motor

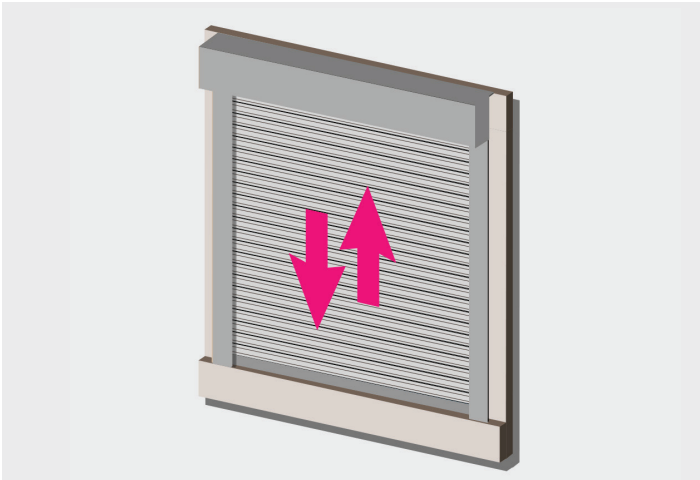

Important to Know:

Motor Limit Switches

All electric motors are equipped with limit switches which automatically stop the curtain at its final positions. The final positions are set during installations. Call your authorized Rollac Dealer if they need adjustment.

Motor Thermal Protection

Motors are equipped with a thermal protection switch. If your motor has been in use for multiple times in succession it might shut off. Depending on outside temperature, wait 25 – 30 min and try operation again.

Maintained Switch

If rolling shutter is equipped with a maintained switch, one press of the button will move the curtain automatically to its final up or down position. To stop curtain in an intermediate position, hit the stop button.

Momentary Switches

If your rolling shutter is equipped with a momentary switch, curtain will move in up or down position. Keep buttons pushed to operate. Release to stop in an intermediate position.

Remote Control

A remote control has an up, down, and stop button. Press up or down button, to move curtain to its final positions. Press the stop button to stop shutter in an intermediate position.

Operation Using The Emergency Override

Only use manual override for emergency operation. The manual override is not designed for long term use. Connect crank handle to pin and operate to raise or lower shutter curtain.

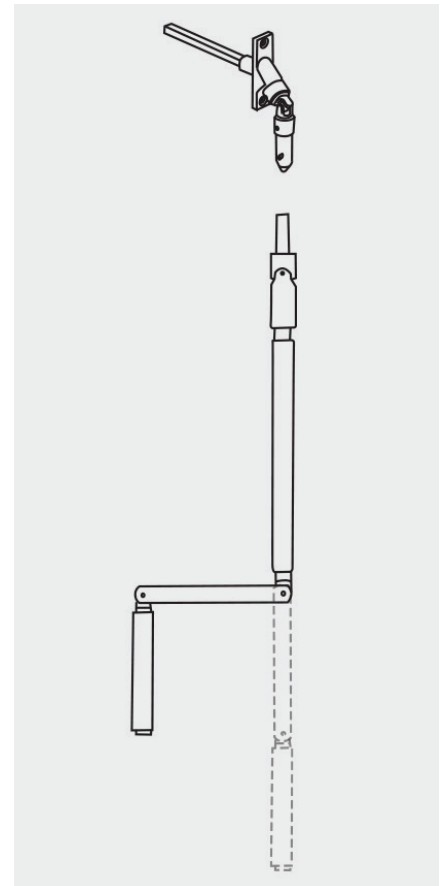

Emergency Override Crank Handle

Shutter Operator Types and How to Use Them

Operation With Tape Drive And Recoil Box

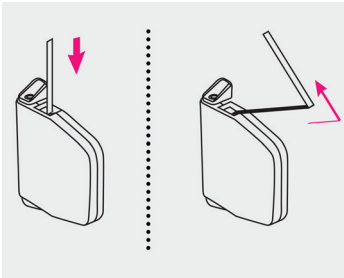

Pull straight down to open the curtain. The higher the curtain rises, the easier the lift. Never let go of the tape. When curtain is within the final third, pull gentler. This will avoid a slamming of the curtain against the mechanical end stop.

To lower the curtain, take the strap close to the recoil box and pull towards you while releasing it slowly. Be certain to hold the tape firmly to avoid abrasion ("rope burn") while the shutter is lowered.

When lowering the shutter, reduce the lowering speed in the final third for a gentle closing

If you feel resistance, do not force Shutter. Rather, locate the cause of resistance or call your Rollac Dealer.

Operation of Gear Crank

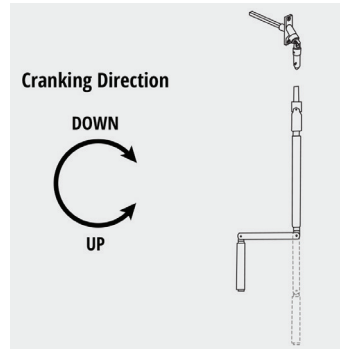

The universal pin is installed to the left or right of the opening. Connect the Crank handle to the pin. Turn crank handle to lower or raise curtain. **DO NOT FORCE.**

The gear has an automatic bottom stop. Before hitting the bottom stop, reduce speed of circular motion to avoid a forceful hit onto bottom stop.

If shutter reaches its stop, do not force it any further as it may cause damage.

If you feel resistance during operation, do not forcefully turn the crank handle. Locate the source of the resistance.

TIP:

If possible, keep crank handle at a 45 degree angle while operating. A large angle will cause stiffness and increased wear and tear on the system.

Operation of Tape Drive and Crank Box

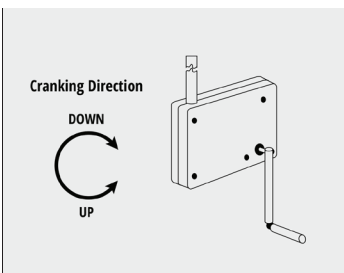

The Tape Drive with Crank Box operates on the same principle as the Tape Drive with Recoil Box System. However, the Gear Crank Box has a gear ratio and is able to lift heavier curtains.

Turn the Crank Handle to raise or lower the curtain. If you feel resistance, **DO NOT FORCE** Shutter. Rather, locate the cause of resistance or call your Rollac Dealer.

The crank handle is removable and can be stored away when not in use.

Spring Loaded Rolling Shutter

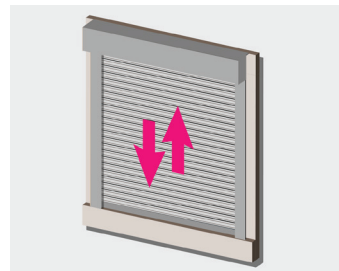

If your rolling shutter is spring loaded it is equipped with a key lock or slide locks.

When opening the curtain, open key lock or slide lock. Guide curtain carefully to its final top position. Avoid slamming of curtain against housing.

When closing the curtain, gently pull down. Lock it in its final down position using the key or slide locks.

General Care and Maintenance Instructions

Care



To ensure the longevity of your rolling shutter, we recommend periodic cleaning of the surface areas. Use a mild detergent and hose off (Do not pressure wash).

Use a dry PTFE lubricant to lubricate guide rails. Do not use WD40.

Ensure that the guide rails are free of any dirt or any other objects.

Never grease the motor or the rolling shutter curtain.

Maintenance

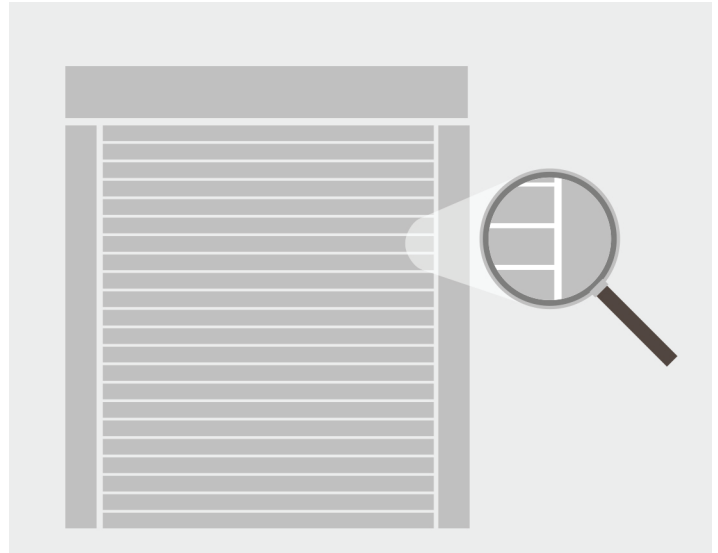

Inspect your rolling shutter at least once a year for wear and tear. Make sure that the rolling shutter is still securely fastened.

Inspection or maintenance of electrical components like adjustment of limit switches can only be performed by your authorized Rollac dealer.

Only use replacement parts from Rollac.

Recommended Service Period:

The recommended service period is once a year. This is based on two cycles per day. One cycle is a full open and close sequence. If the number of cycles is higher, shorten your service period.

Replacement Batteries for Remotes:

Somfy Remote: CR2430

Rollac Remote: 27A

Product Information

Dealer Information

Type of Product	
Operator(s)	
Date of Manufacturer	
Signature Final Check	

Date	Type of Maintenance	Name / Signature of Installer



2 Year Limited Manufacturer's Warranty on Rollac Rolling Shutter

5 Year Limited Manufactured Warranty on Motors

A.) Who Gives the Warranty

Rollac Shutter of Texas, Inc. (Rollac)
5331 W Orange Street, Pearland, Texas 77581

B.) Who is entitled to this Warranty

The warranty applies only to the original residential or commercial purchaser who paid for the product and may not be assigned or transferred to subsequent owners. This warranty applies only to products purchased and installed in the US.

C.) When Does the Warranty Period Start

The warranty period starts with the Date of Invoice to the original purchaser.

D.) What are the responsibilities of Rollac under this warranty?

Subject to the terms and conditions set forth herein, in the event a component fails as a result of a defect in manufacturing, materials, or workmanship within the limited warranty period, Rollac will, at its option (1) provide replacement parts to the Rollac retailer / installer you specify – labor is not included; or (2) provide a factory-authorized repair to the existing component at no cost to you (not including labor for removal, reinstallation, and shipping costs to and from Rollac) or (3) refund of the purchase price at the time of the original purchase, whichever is less. Such replacement parts or repairs are warranted for the remainder of the original warranty period.

E.) What are the responsibilities of the original purchaser

Before any claims may be made under this warranty, the original purchaser must have paid in full for the product covered under the warranty. If the purchaser has failed to make full payments according to the specific pay plan for the product, this warranty shall be null and void and Rollac shall be relieved from any responsibilities or liability under this warranty.

F.) General provisions and limitations

1.) The warranty granted herein is the exclusive remedy for the original purchaser. Rollac makes no other warranties to the purchaser, express, statutory, implied or otherwise. All implied warranties, including but not limited to, implied warranties of merchantability and fitness for a particular purpose, are hereby disclaimed.

2.) To the extent permitted by law, Rollac shall have no liability to the original purchaser or any other person or entity for incidental, special, consequential, indirect, or similar damages of any kind or nature whatsoever, whether arising out of breach of warranty or other breach of contract, negligence or other tort, or otherwise, even if Rollac shall have been advised of the possibility or likelihood of such potential loss or damage. Rollac's liability will in all instances be limited to the repair or replacement or refund of the purchase price of the defective product to the original purchaser, which ever is less. Such damages excluded herein include, but are not limited to, loss of goodwill, loss of profits, incidental injury, loss of use, cost of any substitute product, interruption of business, or any other financial loss.

G.) Claims

All warranty claims must be made during the applicable warranty period. Any claim arising out of any alleged breach of warranty must be brought within two years of such alleged breach. The laws of the State of Texas shall apply to any and all such claims, notwithstanding any conflicts of law provision or doctrine, and the venue for any and all legal actions arising out of such claims shall be in state court in Brazoria County, Texas.

H.) What is not covered by this limited warranty

- The warranty remains only valid if the product is used and maintained by the original purchaser in accordance with the user instructions in the owner's manual. Incorrect or abnormal use will void the warranty
- Normal wear and tear and natural aging. Slight paint abrasion on profiles is inherent to a rolling shutter system and is therefore not covered under this warranty.
- Materials intensively exposed to damaging weather conditions or in an environment with high salt water content.
- Minor color variations between aluminum parts are normal and due to differences in material processing and paint application and excluded from the warranty.
- Rollac assumes no liability for damage to any products and /or components caused by faulty installation, reinstallation or service at the installed location.
- Rollac is not responsible for damage to any structure, to which these products are installed or attached, or to property or items located above, below, or near the rolling shutter (i.e., Glass breakage due to wrong installation or irregular heating of the glazing material).
- Damage caused by third parties such as transport damage, and other irregular circumstances like vandalism or force majeure (damage caused by hurricanes, hail, heavy rain, fire, etc.).
- This warranty does not cover any labor costs and /or installation supplied by your dealer.
- Labor charges, traveling, and any other costs connected with the removal, installation or replacement of parts or products are not covered by this warranty.
- Freight expenses to and from Rollac, or any damage sustained to the product or replacement parts while in transport are not covered by this warranty.
- Installations, repairs or modifications carried out by unauthorized persons will void the warranty.
- The warranty does not cover any costs for demolition or repair if the shutter is not fully accessible or if shutters are built in.
- Use of non compliant parts or parts not approved by Rollac.

I.) How to get help:

For further information or to make a claim within this limited warranty period, please contact the Rollac dealer / retailer who supplied you with your Rollac rolling shutter. If unavailable or unknown to you, you may contact us at:

Rollac Shutter of Texas, Inc.
5331 W Orange Street
Pearland, TX, 77581

www.rollac.com
1.888.276.5522

